



Die Stamped Elbow

Die-Stamped Elbows

Stronger Than Most Competitor's Products

Airtight, welded elbows (die stamped) are available in 45° and 90°. The die stamped elbows run from 3" to 14" and are fabricated from 20 gauge galvanized steel. Centerline Radius (CLR) is 1.5 x diameter. Elbows have 1.5" small end collars slightly less than even inch outside to fit into spiral pipe. All elbows have a smooth obstruction free interior.

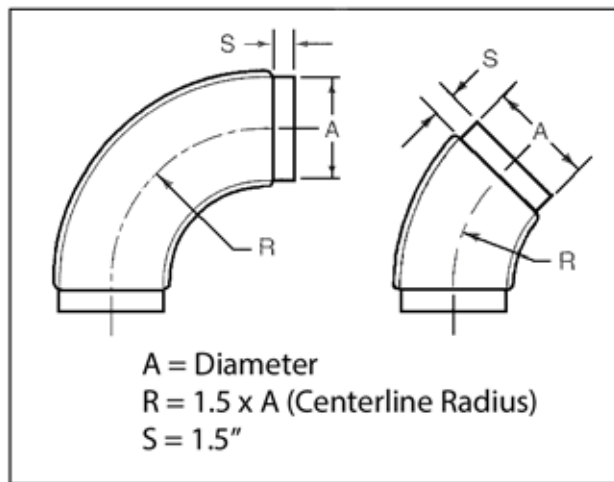

Diameter [A]	EL45 [R]	Weight EL45	EL90 [R]	Weight EL90
3"	4.5	0.8	4.5	1.0
4"	6.0	1.0	6.0	1.5
5"	7.5	1.5	7.5	2.0
6"	9.0	2.0	9.0	3.5
7"	10.5	2.5	10.5	5.0
8"	12.0	3.3	12.0	5.8
9"	13.5	4.0	13.5	7.3
10"	15.0	5.0	15.0	8.5
11"	16.5	6.0	16.5	10.0
12"	18.0	7.0	18.0	13.0
14"	21.0	9.0	21.0	18.0

Due to market changes and fluctuations beyond our control, specifications and pricing subject to change without notice. Buyers subject to terms and conditions of sale. Many states and localities have codes and regulations governing sales, construction, installation and or use of Products for certain purposes, which may vary from those in neighboring areas. While Air Handling Systems by Manufacturers Service Co., Inc. attempts to assure that its Products comply with such codes, it cannot guarantee compliance, and cannot be responsible for how the Product is installed or used. Before purchase and use of a Product, please review the Product application, national & local codes, regulations, and be sure that the Product, installation, and use will be in compliance. Copyright Air Handling Systems.